

Healthy Harvest 5k Run/Walk Sponsored by the Walker Valley Ladies Auxiliary Walker Valley, NY

SPR

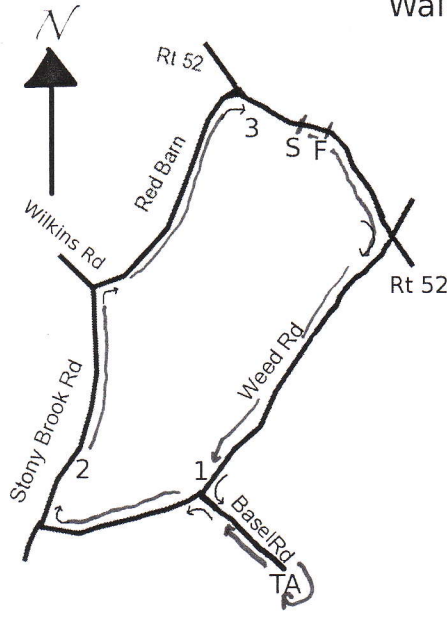

- Key:
 S=Start
 F=Finish
 TP=Telephone pole
 MB=Mailbox
 TA=Turnaround



Certified Course

NY10041JG

Effective: 8/21/2010
 through 12/31/2020

Start in front of Firehouse on Rt 52 in Walker Valley. Go SE on Rt 52, make R onto Weed Rd, pass 1 mile mark (43 ft past TP 966,9), make L onto Basel Rd, reach TA, go back to Weed Rd, go L. Go R onto Stony Brook Rd, pass 2 mile mark, (94.5 ft before TP 2205,6; at driveway for green MB 4). Go R onto Red Barn Rd onto Rt 52, pass 3 mile mark (In line with white line on guardrail for brook under Rt 52). Pass Start line and reach Finish 47 ft later. There will be sufficient room for fire trucks and ambulance to exit.

NYS Route 52

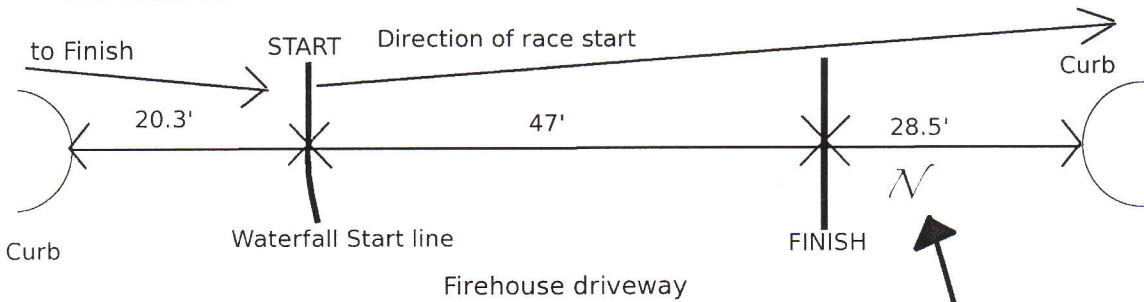
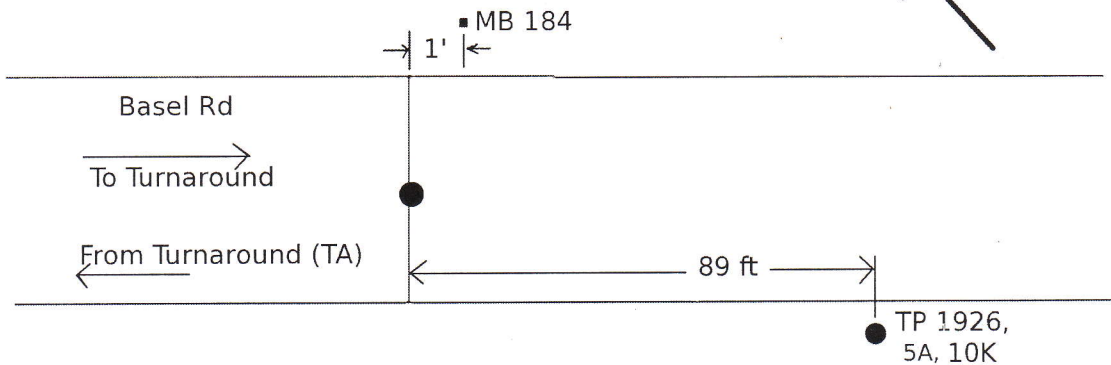

Diagram of turnaround point



Course measurement and marking done by Brian Cavanagh, USATF Certified Coach
www.sullivanstriders.org/brians_sites.htm
 Maps and diagrams done by Kieran Cavanagh.